

## Framed Sliders, Telescopic Panels

Versatile interior partitions designed for office spaces, adaptive re-use projects, multi-family dwellings, mixed-use developments, and event spaces.



[slideclear.com](http://slideclear.com)



#106 – 3425 189 Street,  
Surrey, BC V3Z 1A7



+1-604-888-5399



[info@slideclear.com](mailto:info@slideclear.com)



## Telescopic

SLIDERS

Telescopic glass sliders, also known as telescopic sliding glass doors or partitions, are a type of architectural feature used to divide spaces within a building while maintaining a visual connection between them. These partitions consist of multiple glass panels that slide and stack together to create an open or closed space as needed.

### Functionality:

- The telescopic design allows multiple panels to slide and stack together, maximizing the opening and creating a seamless transition between spaces.
- The design can be customized to fit the overall aesthetic of the interior, with options for different frame finishes and glass type.



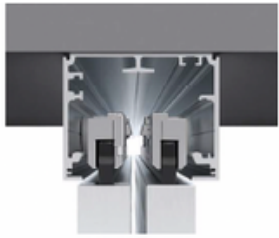
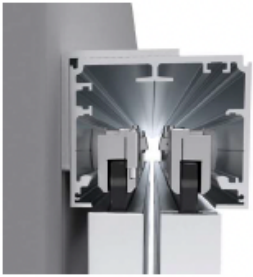

● Ceiling or Wall Mount Installation



● Hardware

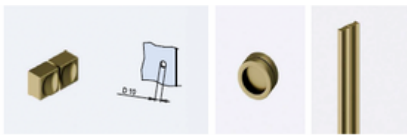

● Aligned framed panels or aligned frameless panels



## Telescopic SLIDERS

### Panel Sizes:

- Minimum: 600 mm
- Maximum: 1000 mm

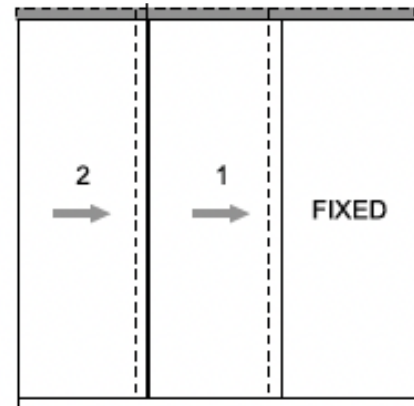
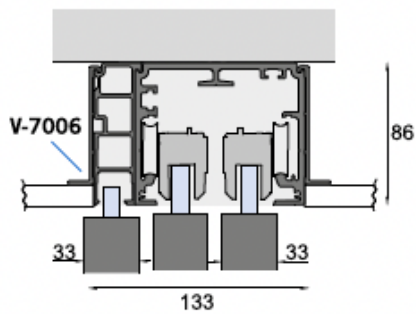
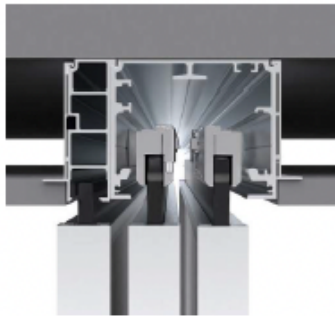

ceiling / Decke

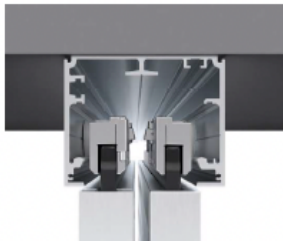

wall / Wand

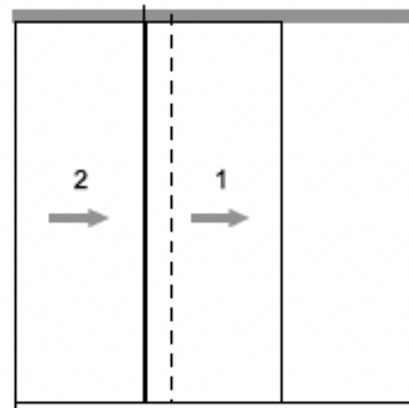
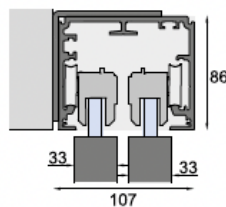
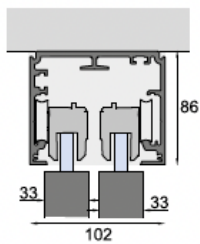
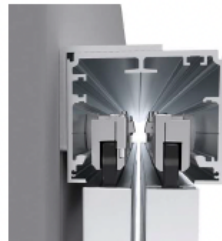



## Framed

### SLIDERS WITH FIXED COMPONENTS

Repurposing absent office spaces for multi-family housing can involve various design considerations, and glass partitions with sliding panels can be an excellent choice to create flexible, open, and visually appealing living spaces. Here are some aspects to consider.

#### Open Concept Design:

- Glass partitions with sliding panels contribute to an open and airy feel, making spaces appear larger and brighter. This is especially important in multi-family housing where maximizing natural light is desirable.

#### Flexibility and Adaptability:

- Sliding glass panels offer flexibility in configuring living spaces. Residents can easily adjust the layout according to their needs, creating a more adaptable and functional environment.

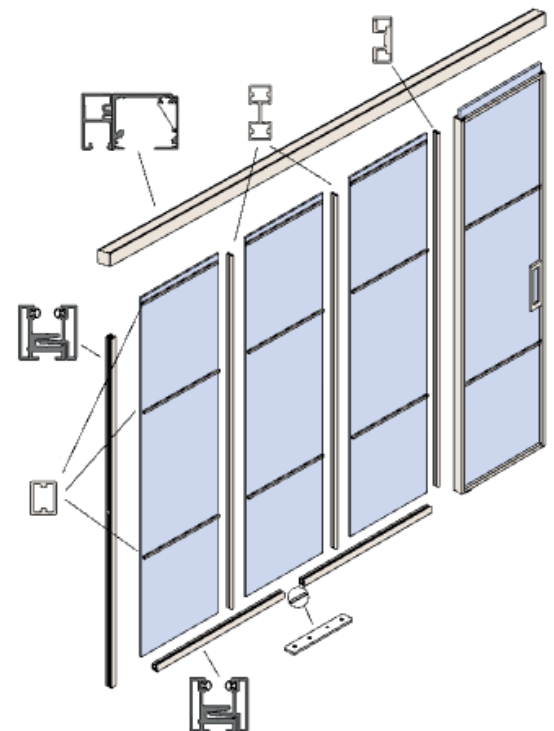

# Framed

## SLIDERS WITH FIXED COMPONENTS

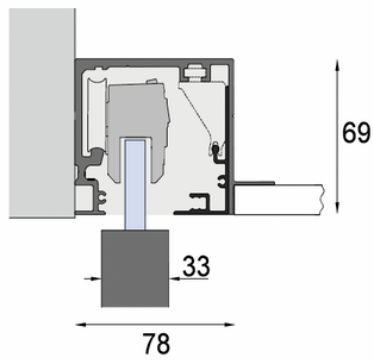
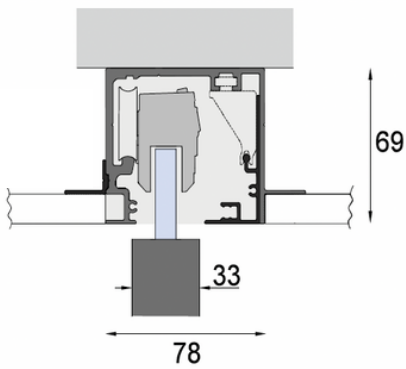
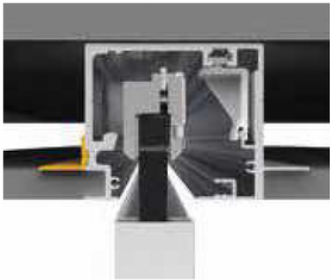

### Panel Sizes:

- Minimum: 500 mm
- Maximum: 1000 mm

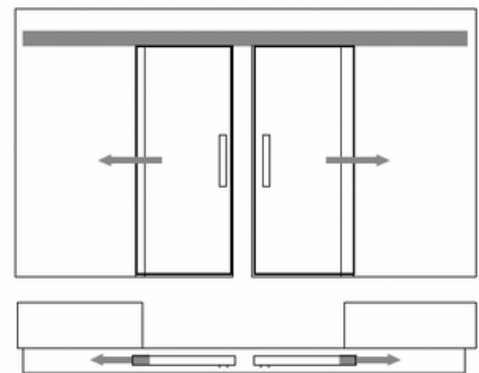
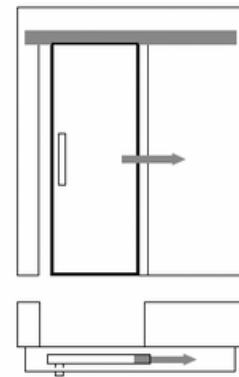

## HARDWARE & FINISHES

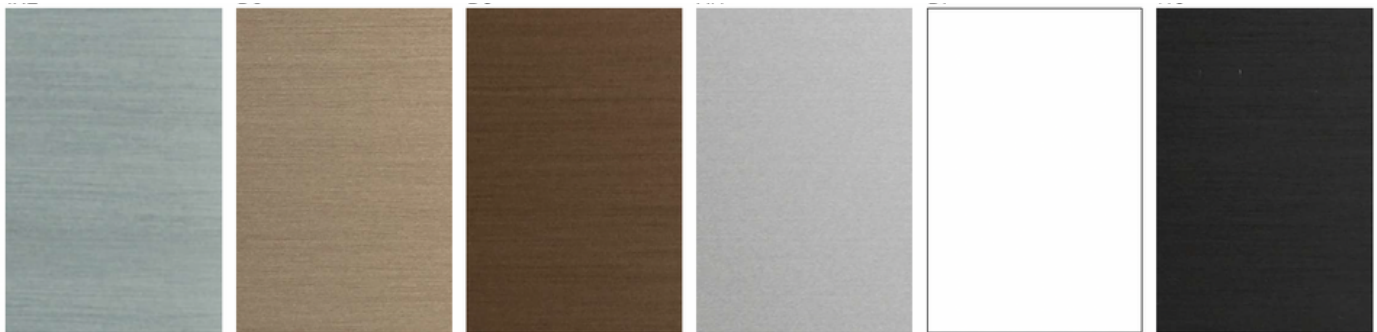
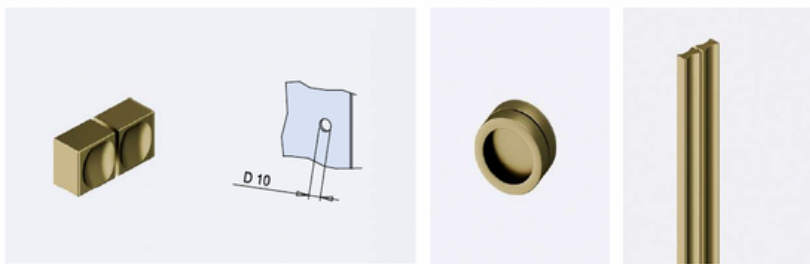

INOX  
Effect

Light  
Bronze

Dark  
Bronze

Silver  
Anodized

Matte  
White

Matte  
Black



Custom Colours

Additional Lead Times & Charges Apply



# FLEXSPACE

Glass Partitions



Consider us as your trusted design partners, not only equipped to answer questions but also dedicated to transforming your ideas into tangible realities. From methodically outlining the ideal plan to executing orders with precision, we function as your collaborators to ensure that your Slide Clear® experience surpasses not only adequacy but approaches a level of exceptional quality.

**[slideclear.com](https://www.slideclear.com)**

Contact Us

Main Office: 1.604.888.5399

Okanagan Office: 1.778.479.8018

Email: [info@slideclear.com](mailto:info@slideclear.com)

Your Direct Contact:

**Christi Dunkley | Director, Market Development**

**a:** Slide Clear #106 – 3425 189 Street  
Surrey, BC V3Z 1A7

**e:** [christi@slideclear.com](mailto:christi@slideclear.com) | **w:** [www.slideclear.com](https://www.slideclear.com)

**m:** (604) 345-9086